



CESCO Magnetics

90 Market Street
Georgetown
Texas 78626 USA



Phone: 707-585-2402
Fax: 707-585-3886
Toll Free: 877-624-8727
cescomagnetics.com

S E R V I N G T H E F O O D I N D U S T R Y S I N C E 1 9 4 6

• QVF • Tank Vacuum Relief Valve



DESCRIPTION:

A sanitary tank vacuum relief valve providing quick action, large flow and minimal accumulation. The non-adjustable low vacuum relief setting is closed under pressure, atmospheric pressure, or partial vacuum. Opens at specified low degree of vacuum and continues to open with increasing vacuum.

USES:

1. Protection of tanks and equipment that can be damage by accidental vacuum such as from faulty discharge pumping, drainage or cooling without venting.
2. General relief at set degree of vacuum.
3. For massive low vacuum relief.

NOTE:

This valve should not be exposed to pressures above 15 PSI or to sudden excessive vacuum caused by rapid condensation of steam.

VALVE SPECIFICATION

Inlet Size	2"	2 1/2"
Height "L"	2 7/8"	3 1/4"
Flow Orifice Dia.	1 3/8"	1 3/4"
Flow Capacity (GPM)	100	175
Stroke "S"	5/16"	7/16"
Actuated Area (sq. in.)	8.3	8.3
Inlet Connection	Tri-Clamp	

Q - US Reg Trade Mark - Covered under US Patent 2902250, 3121444, 3232313 or 3311342 - 3A Authorized

**CESCO builds QUALITY equipment made to your satisfaction.
CESCO for all your magnetic separator needs.**

QVF Tank Vacuum Relief Valve



TEST IN PLACE:

Before relying on this valve for protection during operation, it should be tested in place. Test it using a proper gauge and observe the valve's action under opening vacuum relief and under maximum relief to be assured that the vacuum tolerance of the equipment or tank can not be exceeded.

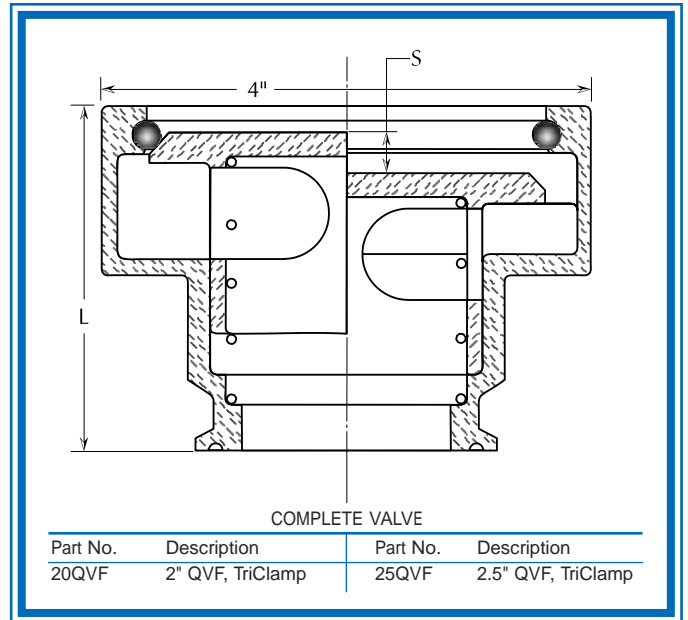

ITEM	Part No.	Description	Material
1	OR338B	O-ring	Buna-N
2	QVF200PL	Plug - 2"	316SS
	QVF250PL	Plug - 2.5	316SS
3	QVF200SP	Spring - 2"	302SS
	QVF250SP	Spring - 2.5"	302SS
4	QVF200BD	Body - 2"	316SS
	QVF250BD	Body - 2.5"	316SS

NOTES:

1. Due to varying conditions of each system, every Q-Control valve should be tested in place before being relied upon for protection during operation.
2. Information presented is general and may not apply to the conditions of individual installation.
3. The manufacturer's warrantee relates to workmanship, sanitary requirements, and action as tested when shipped. Any liability cannot exceed the price of the valve.

